

Linear system **ELZU 30, 40, 60, 60S, 80, 80S, 100**

SURFACE PORTAL

3.1

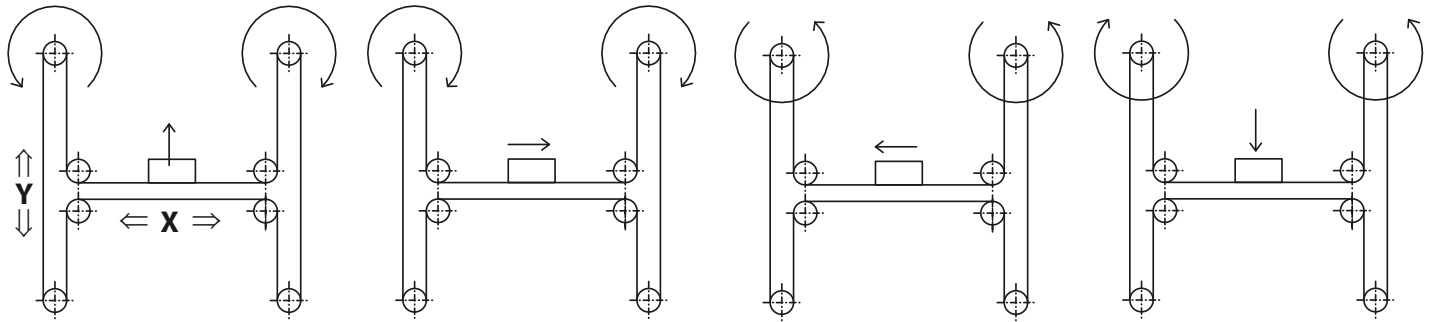

Function:

Surface portal, consisting of 2 Y-axes and 1 X-axis, driven by one rotating belt. This belt runs around different deflection pulleys. Positioning is achieved by two motors. The coordinate is diagonal to the deflection points of the Y-axis.

Advantage: Only small weights are moved, thus enabling high accelerations to be achieved.

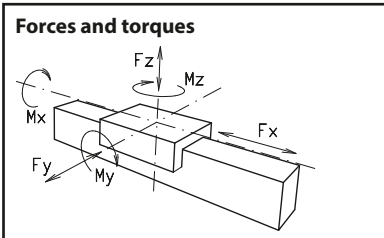

Fitting position:

As required. Max. length and width 3.000 mm.

Carriage mounting:

By T-slots.

Unit mounting:

By T-slots or tapped holes in the bearing block, mounting sets.

Belt type:

HTD with steel reinforcement, no backlash when changing direction, repeatability: ± 0,1 mm.

Size	ELZU 30		ELZU 40		ELZU 60		ELZU 60 S		ELZU 80		ELZU 80 S		ELZU 100	
Forces/Torques	static	dynamic	static	dynamic	static	dynamic	static	dynamic	static	dynamic	static	dynamic	static	dynamic
F _x (N)	200	180	390	350	894	800	894	800	1900	1800	1900	1800	4000	3800
F _y (N)	90	60	1200	700	3000	2000	4100	3100	3000	2000	4600	3600	8000	6500
F _z (N)	90	60	900	650	1700	1100	2160	1600	1700	1100	3000	1800	3600	2200
M _x (Nm)	10	5	25	20	67	43	88	65	90	55	170	140	300	230
M _y (Nm)	13	6	32	18	90	70	190	140	110	80	270	230	400	270
M _z (Nm)	14	7	35	25	120	100	230	170	150	120	300	220	750	500

All forces and torques relate to the following:

existing values $\frac{F_y}{F_{y_{dyn}}} + \frac{F_z}{F_{z_{dyn}}} + \frac{M_x}{M_{x_{dyn}}} + \frac{M_y}{M_{y_{dyn}}} + \frac{M_z}{M_{z_{dyn}}} \leq 1$

table values $\frac{F_y}{F_{y_{dyn}}} + \frac{F_z}{F_{z_{dyn}}} + \frac{M_x}{M_{x_{dyn}}} + \frac{M_y}{M_{y_{dyn}}} + \frac{M_z}{M_{z_{dyn}}} \leq 1$

No-load torque							
Nm	0,2	0,6	1,2	1,2	1,8	1,8	2,6
Speed							
(m/s) max	2	4	5	5	6	6	8
Tensile force							
permanent (N)	200	390	900	900	1900	1900	3600
0,2 s (N)	280	480	1000	1000	2090	2090	4000
Geometrical moments of inertia of aluminium profile							
I _y mm ⁴	4,09x10 ⁴	1,32x10 ⁵	6,79x10 ⁵	6,79x10 ⁵	18,99x10 ⁵	18,99x10 ⁵	44,4x10 ⁵
I _x mm ⁴	4,00x10 ⁴	1,34x10 ⁵	6,97x10 ⁵	6,97x10 ⁵	18,97x10 ⁵	18,97x10 ⁵	44,8x10 ⁵
E-Modulus N/mm ²	70000	70000	70000	70000	70000	70000	70000

For life-time calculation of rollers use our homepage.

Driving torque:

$$M_o = \frac{F \cdot P \cdot S_i}{2000 \cdot \pi} + M_n$$

$$P_o = \frac{M_o \cdot n}{9550}$$

- F = force (N)
- P = pulley action perimeter (mm)
- S_i = safety factor 1,2 ... 2
- M_n = no-load torque (Nm)
- n = rpm pulley (min⁻¹)
- M_o = driving torque (Nm)
- P_o = motor power (KW)

Deflection:

$$f = \frac{F \cdot L^3}{E \cdot I \cdot 192}$$

- f = deflection (mm)
- F = load (N)
- L = free length (mm)
- E = elastic modulus 70000 (N/mm²)
- I = second moment of area (mm⁴)

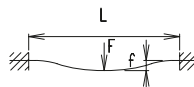

Linear system ELZU 30, 40, 60, 60S, 80, 80S, 100

Dimensions (mm)

3.1

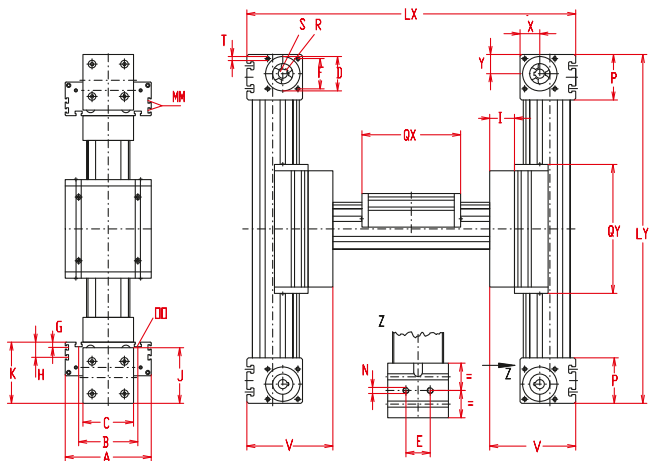

*For slide nuts refer to chapter 2.2 page 2

Size	Basic length		A	B	C	D -0,05	E	F	G	H	I	J	K	MM for	N for	OO for	P	Qx	Qy	T	V	X	Y	Basic weight	Weight per 100 mm
	Lx	Ly																							
ELZU 30	240	210	70	56	42	28	13	25	-	-	27	44	47	-	M 5	M 6	36	82	126	M 5	74	16	16	6,3 kg	0,13 kg
ELZU 40	304	250	100	66	58	37	18	32	-	-	26	58	64	-	M 6	M 6	49	122	147	M 5	90	20,5	20,5	6,8 kg	0,24 kg
ELZU 60	426	330	144	96	80	47	30	42	-	-	33	82	90	-	M 8	M 8	59	168	210	M 6	123	27	26	14,7 kg	0,62 kg
ELZU 60S	450	330	170	108	80	47	30	42	-	-	33	82	94	-	M 8	M 8	59	194	210	M 6	127	27	26	17,7 kg	0,62 kg
ELZU 80	535	435	170	117	100	68	40	60	10,5	30,5	44	110	121	M 6	M 10	M 10	90	194	244	M 8	165	39	38	31,0 kg	1,00 kg
ELZU 80S	555	455	190	126	100	68	40	60	12,5	30	44	110	122	M 6	M 10	M 8	90	214	264	M 8	166	39	38	32,0 kg	1,00 kg
ELZU 100	758	590	230	155	130	90	50	80	-	29	69	135	154	M 10	M 12	M 10	110	300	360	M 10	223	50	50	47,3 kg	1,40 kg

0 Choice of guide body profile:

- (0) Standard (2) corrosion-protected guide rods and screws
- (4) expanded corrosion-protected version (depending on the availability of components)

0 Choice of carriages:

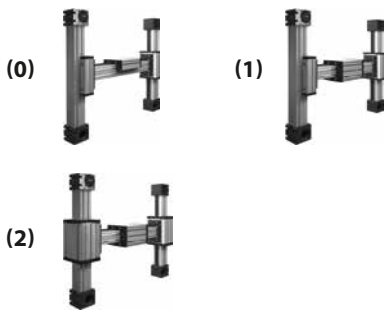

Size	Version 1				Version 2			
	Qx	Lx	Qy	Ly	Qx	Lx	Qy	Ly
30	94	252	126	210	94	252	138	222
40	138	320	147	250	138	320	163	266
60	184	442	210	330	184	442	226	346
60S	214	468	210	330	214	468	230	350
80	210	551	244	435	210	551	260	451
80S	234	575	264	455	234	575	284	475
100	316	774	360	590	316	774	376	606

0 Drive version:

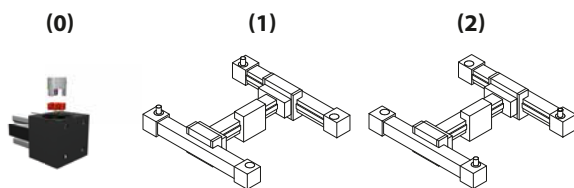

The standard version is supplied without shaft. A shaft can be retrofitted by inserting it into the pulley bore and securing it with 2 locking rings.

Belt table:

Code No.	Size	Belt	mm/rev.	Number of teeth
0 1	30	3M12	75	25
0 3	40	5M15	100	20
0 4	60 (S)	5M25	130	26
0 7	80 (S)	8M30	192	24
0 9	100	8M50	256	32

Shaft dimensions / Coupling claw:

Size	Shaft ø h6 x length	Key	Coupling
30	6 x 15	2x2x12	7
40	10 x 27	3x3x25	9
60 (S)	14 x 35	5x5x28	14
80 (S)	18 x 45	6x6x40	19
100	22 x 45	6x6x40	24

ELZU 60 7 0 0 0 0 4 1 1500

ELZU 60 8 0 0 0 0 4 1 700

Pos. 1 2 3 4 5 6 7

X-Axis Basic length + stroke = total length
Y-Axes Basic length + stroke = total length

For combination kits and connecting elements refer to chapter 2.2

Sample ordering code:

ELZU 60 with standard body profile, standard carriage, coupling claw on one side, stroke X = 1074 / Y = 370 mm

