

Linear system **DST/DSK 120, 160, 200**

SPINDLE DRIVES

 INDEPENDENT INSTALLATION POSITION

 PRECISION

 UNIVERSAL SYSTEM

 HIGH TORQUE ABSORPTION

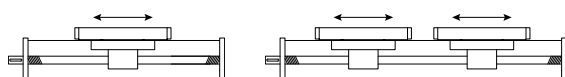
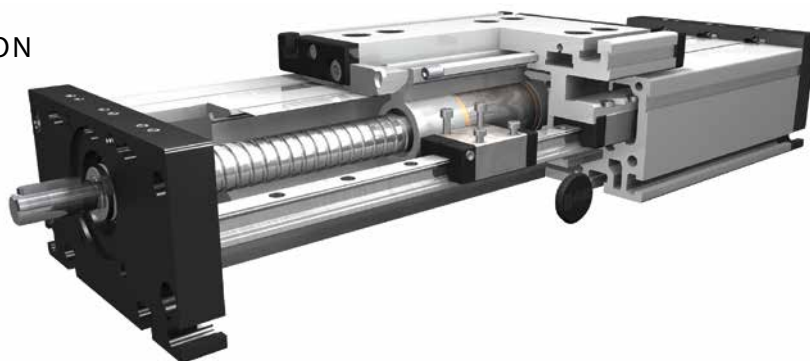

Function:

This unit consists of a rectangular aluminium profile with 2 integrated rail guides. The carriage is driven by means of a rotating spindle with leading nut. Where two parallel linear units are used or where two carriages are mounted on one unit, the leading-nut receiver can be used to adjust the symmetry of the carriages. The openings of the guide body are sealed with 3 stainless steel cover bands to protect the drive from splash water and dust.

Fitting position:

As required. Max. length 3.000 mm without joints.

Carriage mounting:

By T-slots.

Unit mounting:

By T-slots and mounting sets. The linear axis can be combined with any T-slot profile.

Carriage support:

In the standard version, the carriage runs on 4 runner blocks which can be serviced at a central servicing position. For longer carriages the number of runner blocks can be increased.
Repeatability: Ballscrew $\pm 0,025$ mm, trapezoidal thread $\pm 0,2$ mm.

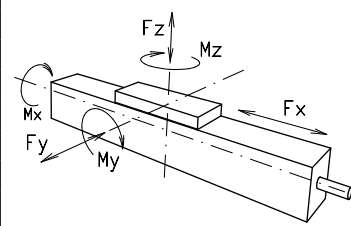
Forces and torques	Size	120		160		200		
	permitted dyn. Forces*	5000 km	10000 km	5000 km	10000 km	5000 km	10000 km	
	F_x (N)	900	800	5000	4000	10000	8000	
	F_y (N)	1776	1405	5570	3900	15600	11080	
	F_z (N)	2090	1650	7050	5020	20600	14600	
	M_x (Nm)	81	64	358	255	1285	915	
	M_y (Nm)	97	77	369	262	1375	980	
	M_z (Nm)	96	76	364	258	1345	960	
All forces and torques related to the following:								
existing values $\frac{F_y}{F_{y_{dyn}}} + \frac{F_z}{F_{z_{dyn}}} + \frac{M_x}{M_{x_{dyn}}} + \frac{M_y}{M_{y_{dyn}}} + \frac{M_z}{M_{z_{dyn}}} \leq 1$								
table values $F_{y_{dyn}}, F_{z_{dyn}}, M_{x_{dyn}}, M_{y_{dyn}}, M_{z_{dyn}}$								
No-load torque								
Trapezoidal thread		18 x 4	18 x 8	24 x 5	24 x 10	32 x 6	32 x 12	
(Nm)		0,8	1,1	1,0	1,3	1,5	1,7	
Ballscrew		16 x 5	16 x 10	25 x 5	20 x 20	32 x 5	32 x 10	32 x 20
(Nm)		0,7	1,0	1,0	1,2	1,3	1,6	1,7
Geometrical moments of inertia of aluminium profile								
I_x mm ⁴		5,61x10 ⁵		2,13x10 ⁶		4,81 x10 ⁶		
I_y mm ⁴		34,19x10 ⁵		12,33x10 ⁶		26,0 x10 ⁶		
Elastic modulus N/mm ²		70000		70000		70000		

* referred to life-time

Driving torque:

$$M_a = \frac{F \cdot P \cdot S_i}{2000 \cdot \pi \cdot \mu} + M_n$$

$$P_a = \frac{M_a \cdot n}{9550}$$

F = force (N)
P = thread pitch (mm)
S_i = safety factor 1,2 ... 2
M_n = no-load torque (Nm)
n = rpm of screw (min⁻¹)
M_a = driving torque (Nm)
μ = screw efficiency
P_a = motor power (KW)

Efficiency of lead screws:

All ballscrew 0,900

Tr 24x5 0,384
Tr 24x10 0,550
Tr 32x6 0,360
Tr 32x12 0,524

Deflection:

$$f = \frac{F \cdot L^3}{E \cdot I \cdot 192}$$

f = deflection (mm)
F = load (N)
L = free length (mm)
E = elastic modulus 70000 (N/mm²)
I = second moment of area (mm⁴)

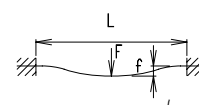

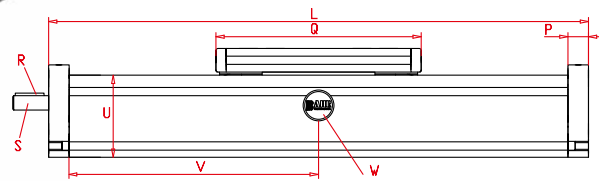
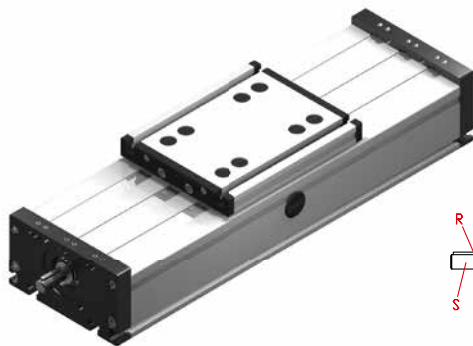
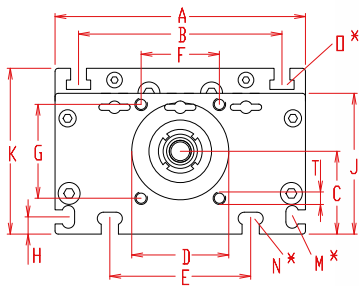

V = Q + 100 mm
W = servicing position

Increasing the carriage length will increase the basic length by the same amount.

Size	Basic length L	A	B	C	D +0,1 +0,05	E	F	G	H	J	K	M for	N for	O for	P	Q	Shaft		T	U	Basic weight	Weight per 100 mm
																	R Key	S Ø h6 x length				
DS 120	200	120	96	39	47	78	42	42	10	68	79	M 5	M 6	M 6	15	156	3x3x25	10 x 27	M 6	60	3,9 kg	0,92 kg
DS 160	260	160	130	53	62	90	50	60	11	90	106	M 6	M 8	M 8	20	200	5x5x28	14 x 35	M 8	80	7,2 kg	2,1 kg
DS 200	320	200	160	66	68	140	60	60	15	110	129	M 8	M 10	M 10	20	270	6x6x40	22 x 45	M 8	100	19,4 kg	3,5 kg

T Spindle:
(T) Trapezoidal thread (K) Ballscrew

1 Selection of screw:
(1) right hand (2) left hand (Ballscrew by inquiry)

0 Choice of guide body profile: Stainless versions upon request.

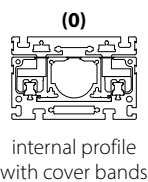

0 Choice of carriages:



Size	Version 0		Version 1	
	Q	L	Q	L
120	156	200	156	200
160	200	260	>230	>290
200	270	320	>310	>360

0 Drive version:
(0) one shaft (locating bearing side) (1) one shaft (non-locating bearing side) (2) shaft on both sides

	Size	Standard	Multistart screw				
Ballscrew right hand	120	(0) 16x5	(1) 16x10	(2) 16x16	(3) 20x20	(4) 25x5	(5) 25x10
	160	(0) 25x5	(1) 20x20	(2) 25x10	(3) 25x25		
	200	(0) 32x5	(1) 32x10	(2) 32x20	(3) 32x32		
Ballscrew left hand	upon request						
Trapezoidal right hand thread	120	(0) 18x4	(1) 18x8				
	160	(0) 24x5	(1) 24x10				
	200	(0) 32x6	(1) 32x12				
Trapezoidal left hand thread	120	(0) 18x4	(1) 18x8				
	160	(0) 24x5	(1) 24x10				
	200	(0) 32x6	(1) 32x12				

0 Ballscrew pitch accuracy:
(0) 0,05 mm / 300 mm (Standard) (2) 0,025 mm / 300 mm

0 End play of ball nut:
(0) 0,04 mm (Standard) (1) < 0,02 mm (2) 2% apply prestress

DS T 160 1 0 0 0 0 0 0 1500 — Basic length + stroke = total length
Pos. 1 2 3 4 5 6 7

Sample ordering code:

DST160, trapezoidal right hand thread, with internal profile and cover bands, standard carriage, one shaft (locating bearing side), spindle 24x5, 1240 mm stroke.

Linear system **DST/DSK 120, 160, 200**

RIGHT-HAND AND LEFT-HAND THREAD OR DIVIDED SPINDLES

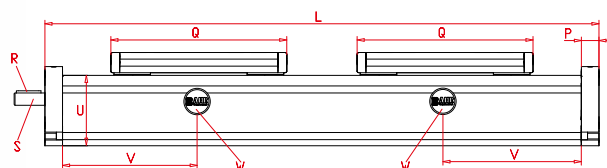
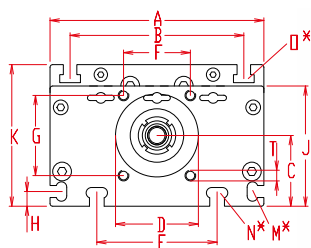

V = Q + 100 mm
W = servicing position

Increasing the carriage length will increase the basic length by the same amount.

Size	Basic length L	A	B	C	D +0,1 +0,05	E	F	G	H	J	K	M for	N for	O for	P	Q	Shaft		T	U	Basic weight	Weight per 100 mm
																	R Key	S Ø h6 x length				
DS 120	360	120	96	39	47	78	42	42	10	68	79	M 5	M 6	M 6	15	156	3x3x25	10 x 27	M 6	60	5,1 kg	0,92 kg
DS 160	470	160	130	53	62	90	50	60	11	90	106	M 6	M 8	M 8	20	200	5x5x28	14 x 35	M 8	80	10,1 kg	2,1 kg
DS 200	590	200	160	66	68	140	60	60	15	110	129	M 8	M 10	M 10	20	270	6x6x40	22 x 45	M 8	100	35,9 kg	3,5 kg

T Spindle:
(T) Trapezoidal thread (K) Ballscrew

3 Selection of screw:
(3) right - left hand (ballscrew by inquiry) (4) divided spindle

0 Choice of guide body profile: Stainless versions upon request.

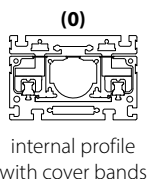

0 Choice of carriages:

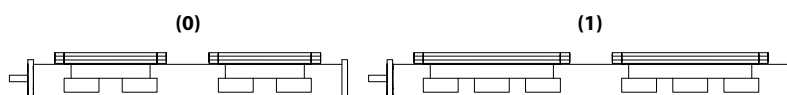

0 Drive version:
(0) shaft right hand thread (1) shaft left hand thread (2) shaft on both sides

Selection of screw:	Size	Standard	Multistart screw				
			(1)	(2)	(3)	(4)	(5)
Ballscrew right hand	120	(0) 16x5	(1) 16x10*	(2) 16x16*	(3) 20x20*	(4) 25x5	(5) 25x10*
	160	(0) 25x5	(1) 20x20*	(2) 25x10*	(3) 25x25*		
	200	(0) 32x5	(1) 32x10*	(2) 32x20*	(3) 32x32*		
Ballscrew left hand	upon request						
Trapezoidal right hand thread	120	(0) 18x4	(1) 18x8				
	160	(0) 24x5	(1) 24x10				
	200	(0) 32x6	(1) 32x12				
Trapezoidal left hand thread	120	(0) 18x4	(1) 18x8				
	160	(0) 24x5	(1) 24x10				
	200	(0) 32x6	(1) 32x12				

* = only for selection of divided spindle

Size	Version 0		Version 1	
	Q	L	Q	L
120	156	360	156	360
160	200	470	>230	>530
200	270	590	>310	>680

0 Ballscrew pitch accuracy:
(0) 0,05 mm / 300 mm (Standard) (2) 0,025 mm / 300 mm

0 End play of ball nut:
(0) 0,04 mm (Standard) (1) < 0,02 mm (2) 2% apply prestress

DS T 160 3 0 0 0 0 0 0 0 0 1500 — Basic length + stroke = total length
Pos. 1 2 3 4 5 6 7

Sample ordering code:

DST160, trapezoidal right - left hand thread, with internal profile and cover bands, standard carriage, shaft on right hand thread, spindle 24x5,1030 mm stroke.