

RACK AND PINION DRIVE

- HIGH LOADS
- HIGH DYNAMICS
- LONG TRAVERSE PATH > 6000 MM
- SPACE SAVING

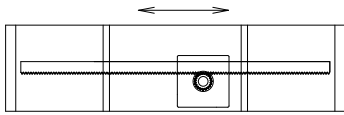
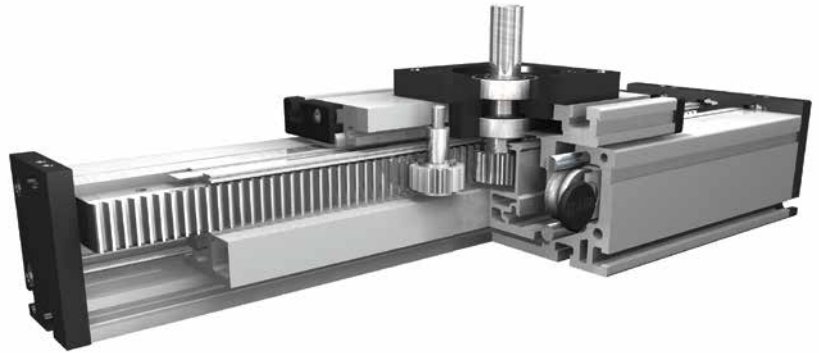

Function:

This unit consists of a rectangular aluminium profile with 2 integrated roller guides. The carriage, which has internal linear ball bearings that can be adjusted free of play, is driven along the guide rods by a high precision rack. The rack and pinion system is suitable for highly dynamic servo operation and ideal for lifting movements. The pinion is equipped with maintenance-free ball bearings. The rack is lubricated by a toothed felt wheel. With this series, multi-part assembled units with long strokes can be realized.

Fitting position:

As required. Max. length 6.000 mm without joints.

Carriage mounting:

By T-slots.

Unit mounting:

By T-slots and mounting sets. The linear axis can be combined with any T-slot profile.

Rack:

6h23 Modul 2 (hardened and ground), repeatability $\pm 0,1$ mm.

Carriage support:

In the standard version, the carriage runs on 8 rollers which can be adjusted and serviced at a central servicing position. For longer carriages the number of rollers can be increased.

Forces and torques	Size	160		200	
	Forces/Torques	static	dynam.	static	dynam.
	F_x (N)	1900	1800	4000	3800
	F_y (N)	3000	2000	4400	3100
	F_z (N)	3500	2800	4900	4400
	M_x (Nm)	400	320	600	510
	M_y (Nm)	360	300	560	480
	M_z (Nm)	180	150	310	275
All forces and torques related to the following:					
existing values $\frac{F_y}{F_{y_{dyn}}} + \frac{F_z}{F_{z_{dyn}}} + \frac{M_x}{M_{x_{dyn}}} + \frac{M_y}{M_{y_{dyn}}} + \frac{M_z}{M_{z_{dyn}}} \leq 1$					
table values					
No-load torque					
Nm		1,5		2,6	
Speed					
(m/s) max		3		5,0	
Tensile force					
permanent (N)		1900		3000	
Geometrical moments of inertia of aluminium profile					
I_x mm ⁴		22,2x10 ⁵		63,8x10 ⁵	
I_y mm ⁴		122,0x10 ⁵		335x10 ⁵	
Elastic modulus N/mm ²		70000		70000	

Driving torque:

$$M_o = \frac{F \cdot P \cdot S_i}{2000 \cdot \pi} + M_n$$

$$P_o = \frac{M_o \cdot n}{9550}$$

F = force (N)
 P = pulley action perimeter (mm)
 Si = safety factor 1,2 ... 2
 Mn = no-load torque (Nm)
 n = rpm pulley (min⁻¹)
 Mo = driving torque (Nm)
 Po = motor power (KW)

Deflection:

$$f = \frac{F \cdot L^3}{E \cdot I \cdot 192}$$

f = deflection (mm)
 F = load (N)
 L = free length (mm)
 E = elastic modulus 70000 (N/mm²)
 I = second moment of area (mm⁴)

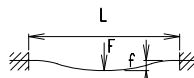

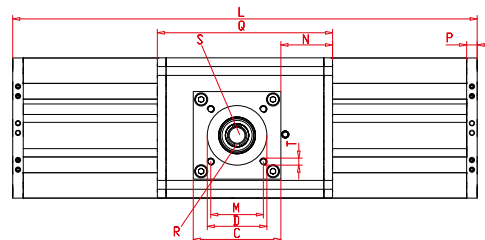
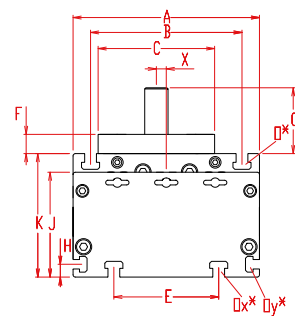
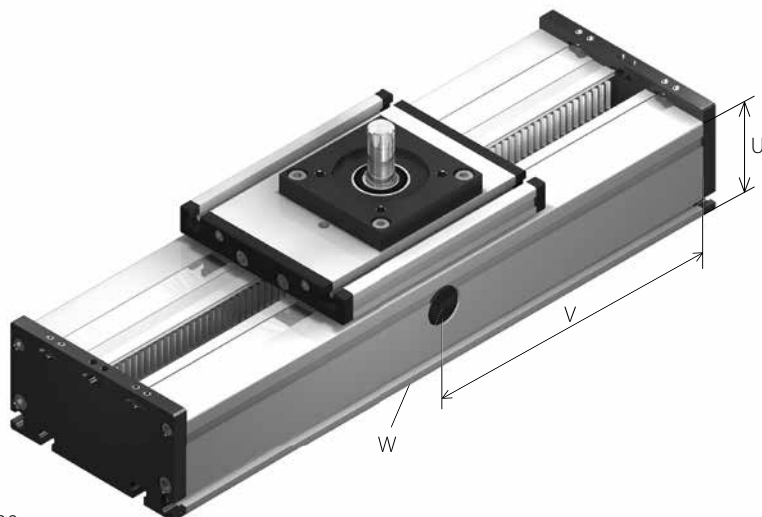

V = Q + 100 mm
W = servicing position

Increasing the carriage length will increase the basic length by the same amount.

Size	Basic length L	A	B	C	D ±0,05	E	F	G	H	J	K	M	N	O for	Ox for	Oy for	P	Q	T for	U	X	Basic weight	Weight per 100 mm
DLZA 160	240	160	130	100	68	90	16,5	56,5	11	90	106	60	59	M 8	M 8	M 6	12	200	M 8	80	8,5	13,0 kg	2,10 kg
DLZA 200	320	200	160	120	90	140	20	45	15	110	129	80	95	M 10	M 10	M 8	15	270	M 8	100	5	28,9 kg	6,15 kg

0 Choice of guide body profile: Stainless versions upon request.

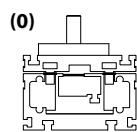

internal profile with cover bands

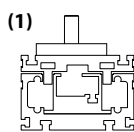

internal profile without cover bands

0 Choice of carriage:

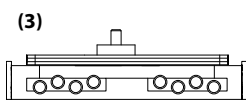
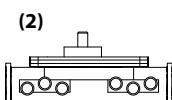
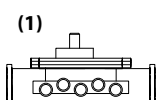
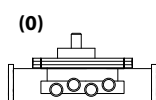

Size	Version 0		Version 1		Version 2		Version 3	
	Q	L	Q	L	Q	L	Q	L
160	200	240	250	290	>300	>340	--	--
200	270	320	330	380	>410	>460	>535	>580

1 Drive version:

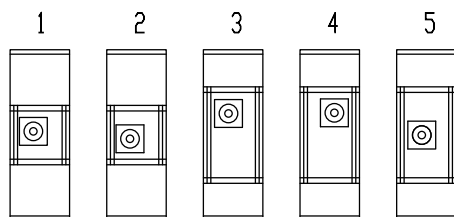

Shaft dimensions:

Size	Shaft ø h6 x length	Key	Pinion	
	S	R	mm/rev.	Modul
160	20 x 40	6x6x35	100,53	2
200	18 x 25	6x6x20	94,25	2

DLZA 160 1 0 0 1 0 0 1 1500 — Basic length + stroke = total length
Pos. 1 2 3 4 5 6 7

Sample ordering code:
DLZA160 with internal profile and cover bands, standard carriage, 1260 mm stroke.