

TA16

series



Product Segments

- **Care Motion**
- **Comfort Motion**
- **Ergo Motion**
- **Industrial Motion**

TiMOTION's TA16 series linear actuator is similar to the TA2 linear actuator, but is specifically designed for low-noise medical applications where a compact linear actuator is needed. It is available with optional IP66 protection and Hall sensors for position feedback. Certificates for the TA16 include IEC60601-1, ES60601-1, IEC60601-1-2, UL962, and EMC.

General Features

Max. load	3,500N (push/pull)
Max. speed at max. load	6.2mm/s
Max. speed at no load	23.5mm/s
Retracted length	≥ Stroke + 112mm
IP rating	IP66
Certificate	IEC60601-1, ES60601-1, IEC60601-1-2, UL962, EMC
Stroke	20~600mm
Options	POT, Hall sensor(s)
Voltage	12, 24, 36, 48V DC
Color	Silver
Operational temperature range at full performance	+5°C~+45°C
With very low noise, small size for easy installation	
Suitable for patient hoist application	

Drawing

Dimensions
without Output Signal
or with Hall Sensors
(mm)

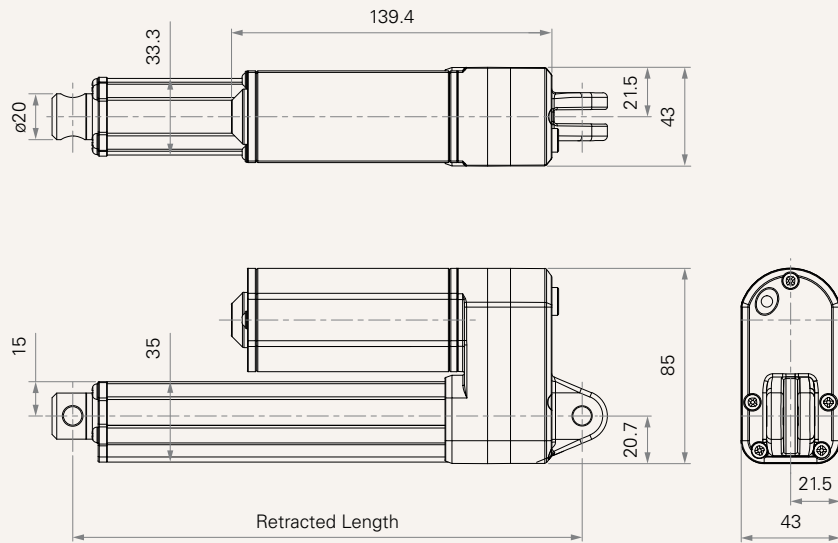

Dimensions with POT
(mm)

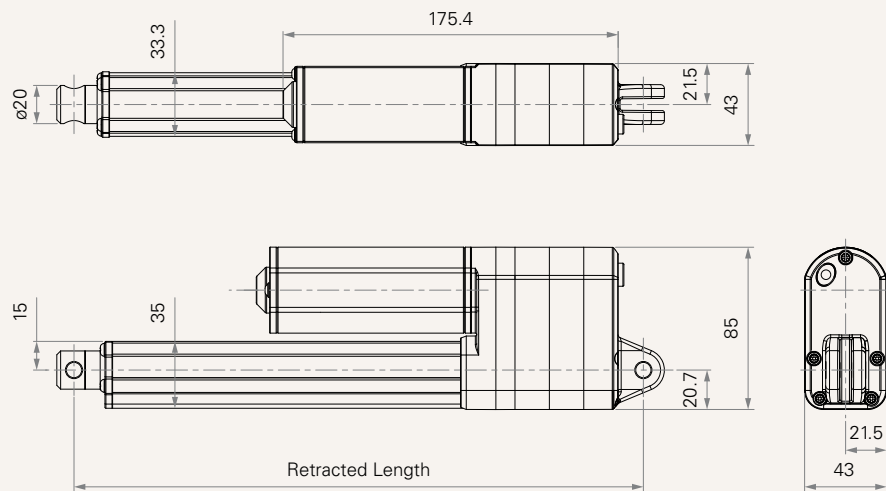

Load and Speed

CODE	Load (N)		Self Locking Force (N)	Typical Current (A)		Typical Speed (mm/s)	
	Push	Pull		No Load 32V DC	With Load 24V DC	No Load 32V DC	With Load 24V DC
Motor Speed (3800RPM, Duty Cycle 10%)							
A	2500	2500	2500	1.7	2.6	5.2	3.0
B	2000	2000	2000	1.7	2.6	8.3	4.7
C	1500	1500	1500	1.7	2.6	11.9	7.0
D	1000	1000	1000	1.7	2.6	17.7	10.3
Motor Speed (5200RPM, Duty Cycle 10%)							
G	3500	3500	3500	2.0	4.7	11.0	6.2
J	2000	2000	2000	2.0	3.7	17.0	10.5
K	1500	1500	1500	2.0	3.5	23.5	13.5

Note

- 1 Please refer to the approved drawing for the final authentic value.
- 2 This self-locking force level is reached only when a short circuit is applied on the terminals of the motor. All the TiMOTION control boxes have this feature built-in.
- 3 The current & speed in table are tested with 24V DC motor. With a 12V DC motor, the current is approximately twice the current measured in 24V DC. With a 36V DC motor, the current is approximately two-thirds the current measured in 24V DC. With a 48V DC motor, the current is approximately half the current measured in 24V DC. Speed will be similar for all the voltages.
- 4 The current & speed in table and diagram are tested with TiMOTION control boxes, and there will be around 10% tolerance depending on different models of the control box. (Under no load condition, the voltage is around 32V DC. At rated load, the voltage output will be around 24V DC)
- 5 Standard stroke: Min. ≥ 20 mm, Max. please refer to below table.

CODE	Load (N)	Max Stroke (mm)
G	≤ 3500	300
A	≤ 2500	400
B, J	≤ 2000	450
C, K	≤ 1500	500
D	≤ 1000	600

Performance Data (24V DC Motor)

Motor Speed (3800RPM, Duty Cycle 10%)

Speed vs. Load

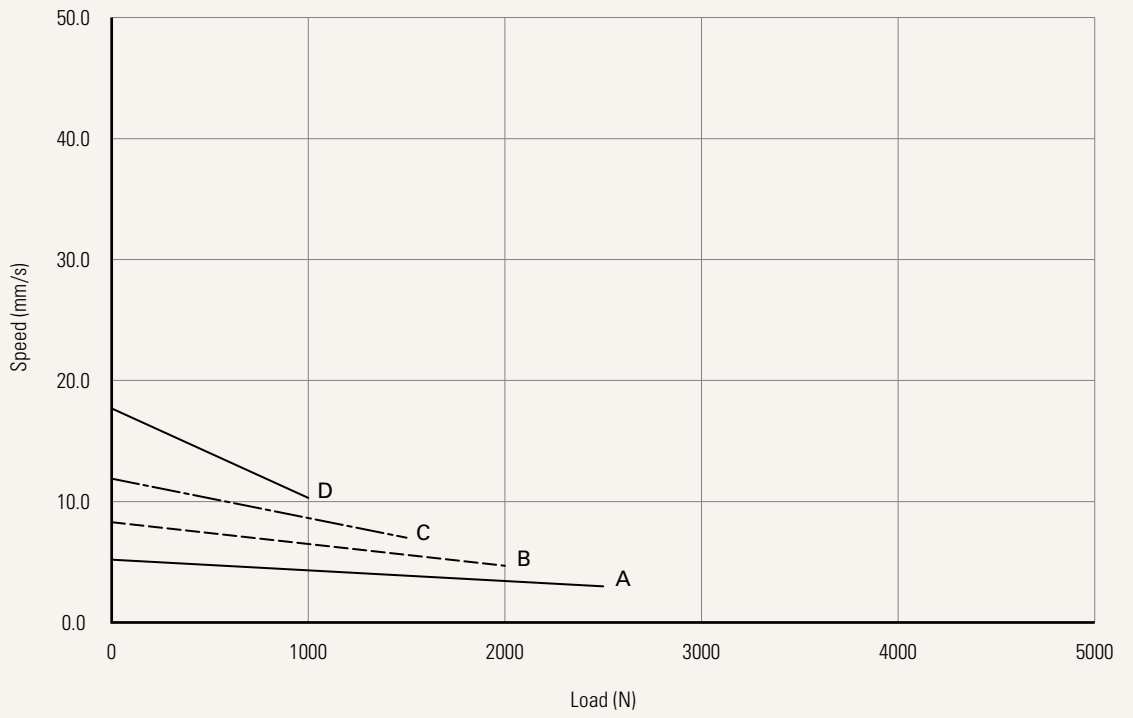

Current vs. Load

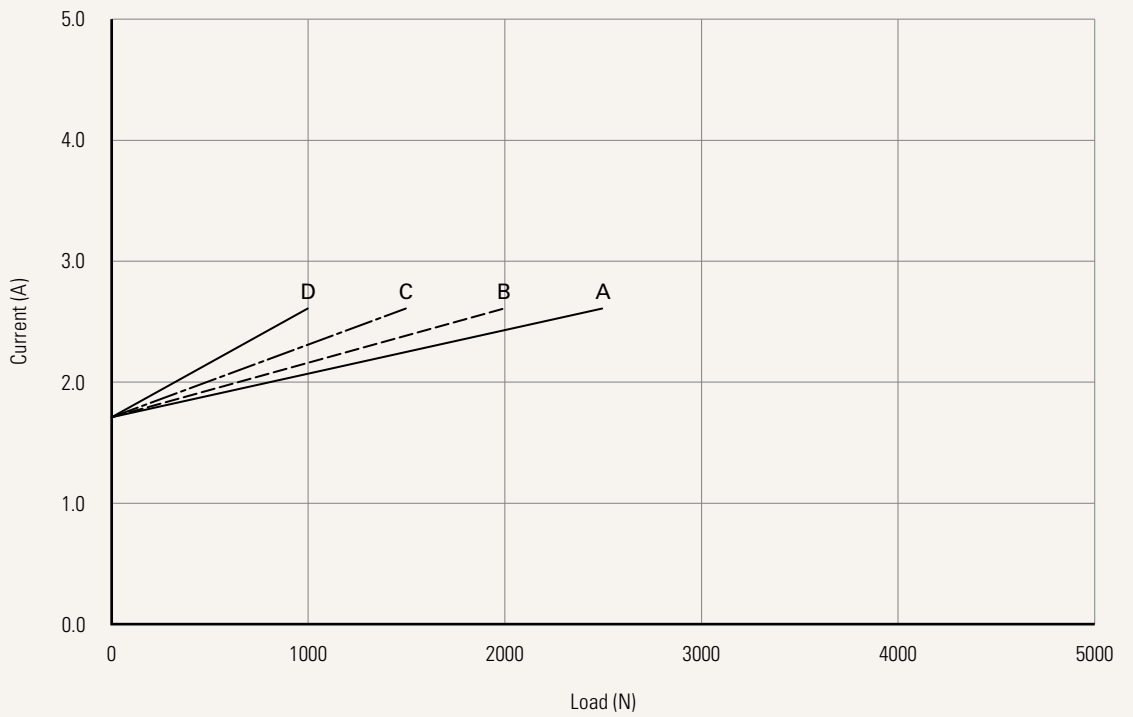

Performance Data (24V DC Motor)

Motor Speed (5200RPM, Duty Cycle 10%)

Speed vs. Load

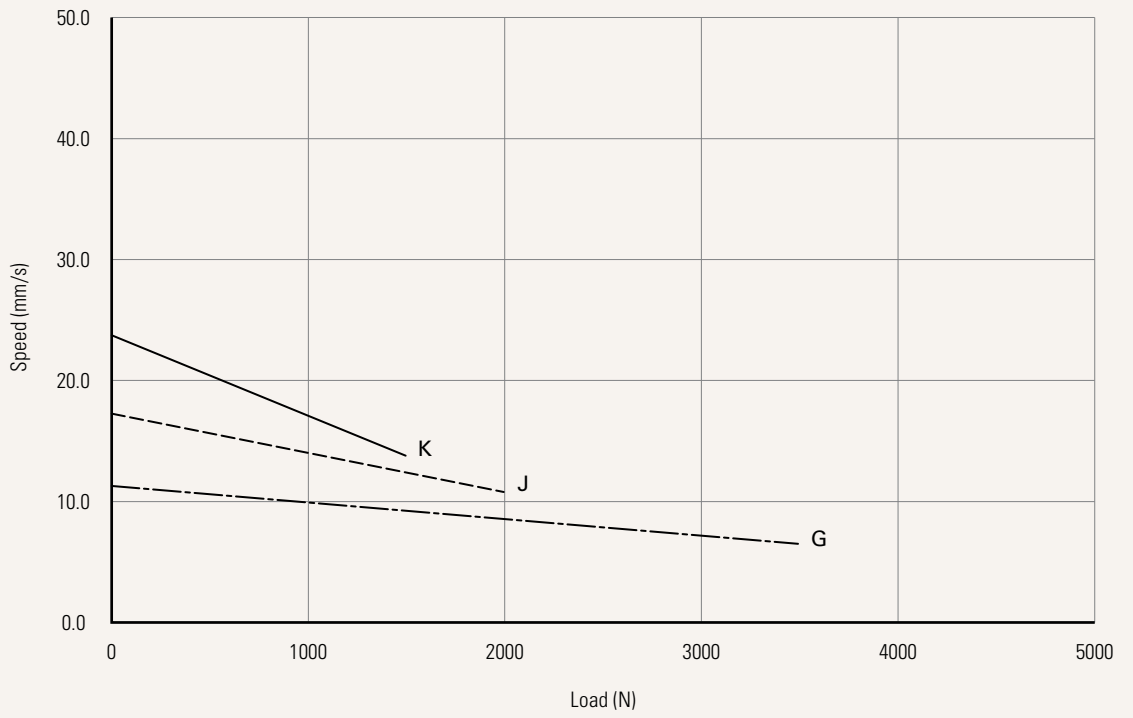

Current vs. Load

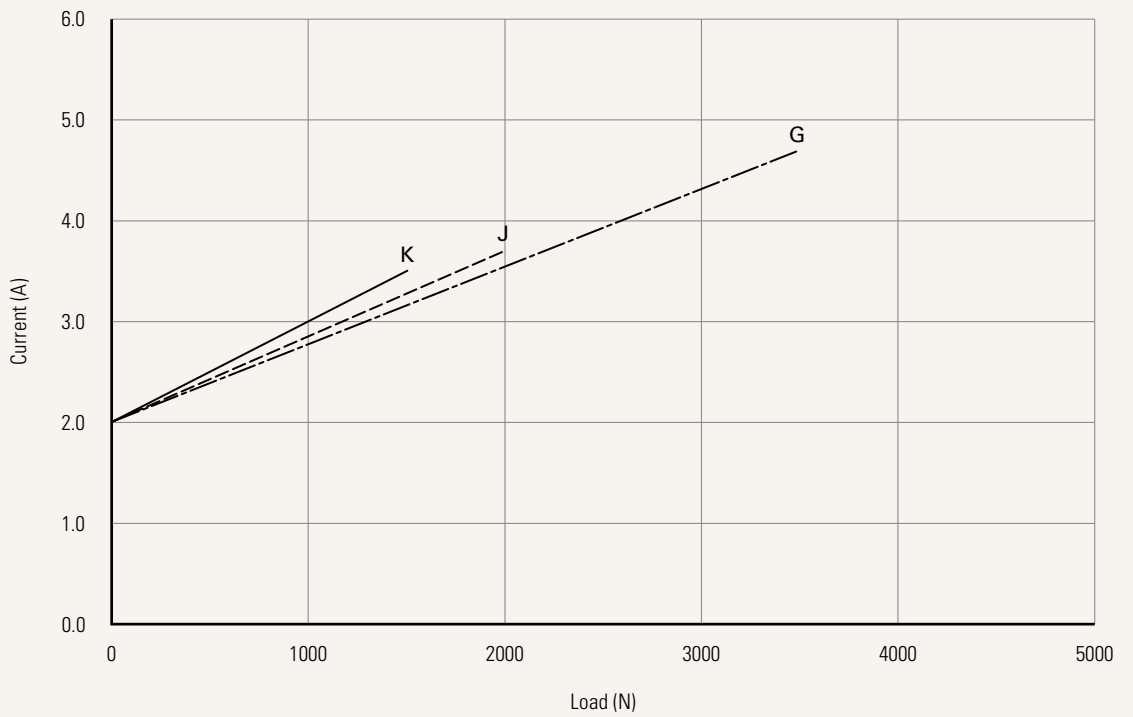

Voltage	1 = 12V DC	2 = 24V DC	3 = 36V DC	4 = 48V DC
Load and Speed	See page 3			
Stroke (mm)	See page 3			
Retracted Length (mm)	See page 7			
Rear Attachment (mm) See page 8	1 = Aluminum casting, U clevis, width 6.0, depth 12.2, hole 6.4, one piece casting with gear box 2 = Aluminum casting, U clevis, width 6.0, depth 12.2, hole 8.0, one piece casting with gear box 3 = Aluminum casting, U clevis, width 6.0, depth 12.2, hole 10.0, one piece casting with gear box			
Front Attachment (mm) See page 8	1 = Aluminum casting, no slot, hole 6.4 2 = Aluminum casting, no slot, hole 8.0 3 = Aluminum casting, no slot, hole 10.0 4 = Aluminum casting, U clevis, width 6.0, depth 13.0, hole 6.4		5 = Aluminum casting, U clevis, width 6.0, depth 13.0, hole 8.0 6 = Aluminum casting, U clevis, width 6.0, depth 13.0, hole 10.0	
Direction of Rear Attachment (Counterclockwise) See page 8	1 = 90°		2 = 0°	
IP Rating	1 = Without	2 = IP54	3 = IP66	
Functions for Limit Switches See page 9	1 = Two switches at full retracted / extended positions to cut current 2 = Two switches at full retracted / extended positions to cut current + 3rd LS to send signal 3 = Two switches at full retracted / extended positions to send signal 4 = Two switches at full retracted / extended positions to send signal + 3rd LS to send signal			
Special Functions for Spindle Sub-Assembly	0 = Without (Standard) 1 = Safety nut		2 = Standard push only 3 = Standard push only + safety nut	
Output Signals	0 = Without	1 = POT	4 = Hall sensor * 1	5 = Hall sensor * 2
Connector See page 9	1 = DIN 6P, 90° plug 2 = Tinned leads 4 = Big 01P, plug	C = Y cable (For direct cut system, water proof, anti pull) E = Molex 8P, plug F = DIN 6P, 180° plug		G = Audio plug
Cable Length (mm)	0 = Straight, 100 1 = Straight, 500 2 = Straight, 750	3 = Straight, 1000 4 = Straight, 1250 5 = Straight, 1500	6 = Straight, 2000 7 = Curly, 200 8 = Curly, 400	B-H = For direct cut system See page 9

Retracted Length (mm)

1. Calculate $A+B+C+D = Y$
2. Retracted length needs to \geq Stroke + Y

A. Rear / Front Attachment

Front Attachment	Rear Attachment
	1, 2, 3
1, 2, 3	+112
4, 5, 6	+122

B. Load V.S. Stroke

Stroke (mm)	Load (N)	
	< 3500	= 3500
20~150	-	+13
151~200	+8	+21
201~250	+8	+21
251~300	+13	+26
301~350	+13	+26
351~400	+18	+31
401~450	+23	+36
451~500	+28	+41
501~550	+33	+46
551~600	+38	+51

C. Load V.S. Spindle Functions

Spindle Functions	Load (N)		
	A, B	G	C, D, J, K
0	-	-	-
1	+10	+5	+10
2	+2	+2	+2
3	+12	+7	+12

D. Output Signals

CODE	
0, 4, 5	-
1	+36

Rear Attachment (mm)

1 = Aluminum casting, U clevis, width 6.0, depth 12.2, hole 6.4, one piece casting with gear box

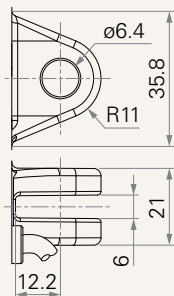

2 = Aluminum casting, U clevis, width 6.0, depth 12.2, hole 8.0, one piece casting with gear box

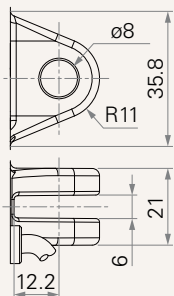

3 = Aluminum casting, U clevis, width 6.0, depth 12.2, hole 10.0, one piece casting with gear box

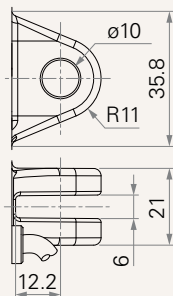

Front Attachment (mm)

1 = Aluminum casting, no slot, hole 6.4

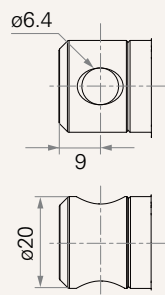

2 = Aluminum casting, no slot, hole 8.0

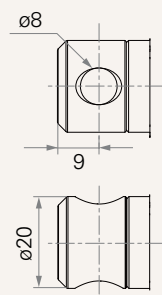

3 = Aluminum casting, no slot, hole 10.0

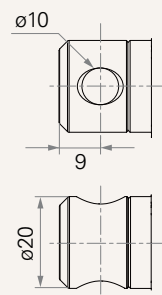

4 = Aluminum casting, U clevis, width 6.0, depth 13.0, hole 6.4

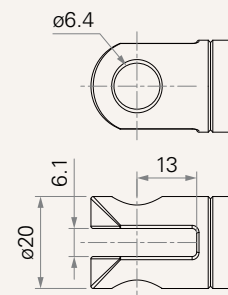

5 = Aluminum casting, U clevis, width 6.0, depth 13.0, hole 8.0

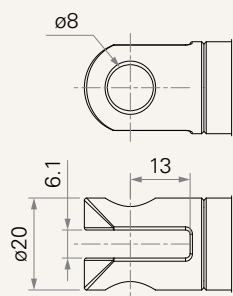

6 = Aluminum casting, U clevis, width 6.0, depth 13.0, hole 10.0

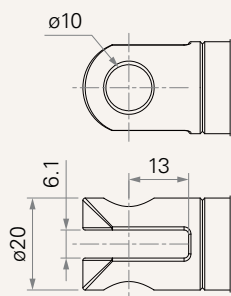

Direction of Rear Attachment (Counterclockwise)

1 = 90°

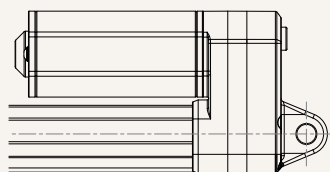

2 = 0°

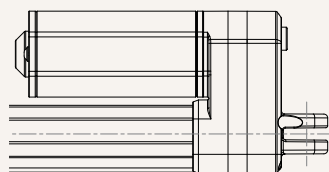

Functions for Limit Switches

Wire Definitions

CODE	Pin					
	● 1 (Green)	● 2 (Red)	○ 3 (White)	● 4 (Black)	● 5 (Yellow)	● 6 (Blue)
1	extend (VDC+)	N/A	N/A	N/A	retract (VDC+)	N/A
2	extend (VDC+)	N/A	middle switch pin B	middle switch pin A	retract (VDC+)	N/A
3	extend (VDC+)	common	upper limit switch	N/A	retract (VDC+)	lower limit switch
4	extend (VDC+)	common	upper limit switch	medium limit switch	retract (VDC+)	lower limit switch

Connector

1 = DIN 6P, 90° plug

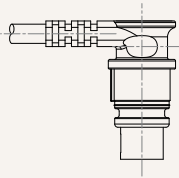

2 = Tinned leads

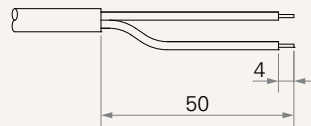

4 = Big 01P, plug

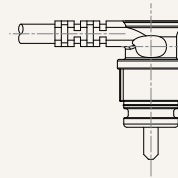

C = Y cable (For direct cut system, water proof, anti pull)

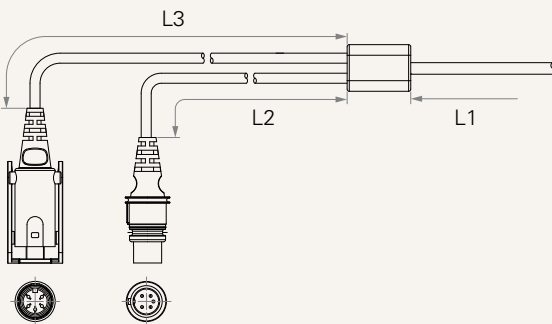

Cable length for direct cut system (mm)

CODE	L1	L2	L3
B	100	100	100
C	100	1000	400
D	100	2700	500
E	1000	100	100
F	100	600	1000
G	1500	1000	1000
H	100	100	1200

E = Molex 8P, plug

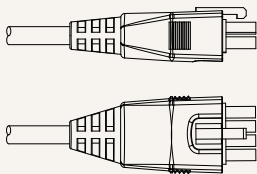

F = DIN 6P, 180° plug

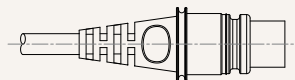

G = Audio plug



Terms of Use

The user is responsible for determining the suitability of TiMOTION products for a specific application. TiMOTION products are subject to change without prior notice.